

ALTIUS

PROTECT YOUR WARRANTY

**This unit must be installed by a registered,
licensed installer as required by
Government regulations.**



5 kWh Home Battery

Installation Manual

Model Number: AS-5KW-LB2

Contents

03	Important Safety Information
06	Product Overview
09	Getting Started
10	Installation
23	Startup and Shutdown Procedure
24	Equipment Interface Instructions
25	Operations
26	Troubleshooting
28	Other Useful Information
33	Installer's Notes

Important Safety Information

IMPORTANT SAFETY INSTRUCTIONS READ CAREFULLY AND KEEP FOR FUTURE REFERENCE

Read this manual thoroughly before first use, even if you are familiar with this type of product. The safety precautions enclosed herein reduce the risk of fire, electric shock and injury when correctly adhered to. Keep the manual in a safe place for future reference, along with the completed warranty card, purchase receipt and carton. If applicable, pass these instructions on to the next owner of the appliance.

Always follow basic safety precautions and accident prevention measures when using an electrical appliance, including the following:

WARNING: Electric shock hazard - professional installation only!

- This appliance must be professionally installed to an appropriately earthed wiring system by a licensed installer, following the instructions in this manual.
- Ensure to make these instructions available to the installer. Failure to install the appliance correctly could invalidate any warranty or liability claims.
- Alterations to the domestic wiring system must only be made by a qualified electrician. Failure to follow this advice may result in electric shock or death.

General usage conditions and restrictions

- **Installation location:** This battery is designed for indoor use only.
- **Installation parameters:** This battery must be wall-mounted at least 1 m away from the floor, and at least 50 cm from any walls or other batteries. It must be installed in the shade, at least 5 m away from any heat source.
- **WARNING! This equipment is not suitable for use in locations where children are likely to be present.**
- **Intended purpose:** Only use this battery for its intended purpose, in its intended environment and as described in this manual. Any other use may cause fire, electric shock or injury.
- **Follow instructions:** Make sure to observe all rules and provisions in this manual. These instructions are not intended to cover every possible condition and situation. As with any product such as this, use common sense and caution when installing, operating and maintaining.

Electrical Safety

- **WARNING! High Voltage:** Any object - particularly a wet object - coming into contact with a high voltage power supply (directly or indirectly) can cause serious injury or death.
- **Tools:** When working with high voltage and AC power, be sure to only use the required, special-purpose tools.

Important Safety Information (Cont.)

- **Static electricity:** Any static electricity could damage veneer on the electrostatic sensitive components. Before touching the plug in, circuit board or chips, be sure to use correct electrostatic prevention measures.
- **WARNING! Power supply:** When installing or maintaining this battery, the power supply must be disconnected first.
- **Short circuit:** The power system provides a DC regulated power supply. DC short circuit could cause serious damage to the equipment.
- **Battery top:** Do not rest any items on top of the battery.
- **CAUTION! Charging temperature range:** The temperature range at which the battery can be charged is 0 °C to 55°C. Charging the battery at temperatures outside of this range may cause damage to the battery and/or its surroundings. Charging the battery outside of this temperature range may also harm the performance of the battery or reduce the battery's life expectancy.
- **CAUTION! Discharging temperature range:** The temperature range at which the battery can be discharged is -10 °C to 55° C. Use of the battery outside of this temperature range may damage the performance of the battery or may reduce its life expectancy.
- **DANGER! Discharging device:** Do not discharge the battery using anything other than the specified device. When the battery is used in devices aside from this, it may damage the performance of the battery or reduce its life expectancy. Additionally, if the device causes an abnormal current to flow, it may cause the battery to become hot and cause serious injury.
- **WARNING! Hazardous Voltage:** The battery system operates with hazardous voltages. Installation, maintenance and repairs must ONLY be carried out by qualified personnel.
- **DANGER! Battery Cells:** Even after the unit is disconnected from the mains, components inside are still connected to the battery cells which are potentially dangerous.
- **WARNING! Disconnecting:** Before carrying out any kind of service and/or maintenance, disconnect the batteries and verify that no current is present and no hazardous voltage exists in the terminals.
- **WARNING! Authorised personnel:** Only persons are adequately familiar with batteries and with the required precautionary measures may replace batteries and supervise operations. Unauthorized persons must be kept well away from the batteries.

Important Safety Information (Cont.)

- **DANGER! Battery terminals:** Verify that no voltage between the battery terminals and the ground is present before maintenance or repair. In this product, the battery circuit is not isolated from the input voltage. Hazardous voltages may occur between the battery terminals and the ground.
- **WARNING! Metal items:** Batteries may cause electric shock and have a high short-circuit current. Please remove all wristwatches, rings and other metal personal objects before maintenance or repair, and only use tools with insulated grips and handles for maintaining or repairing.
- **WARNING! Replacements:** When replacing the batteries, install the same number and same type of batteries.
- **WARNING! Parallel:** When replace the parallel batteries, make sure the new battery is full charged.
- **WARNING! Do not open or destroy batteries.** Escaping electrolyte can cause injury to the skin and eyes. It may be toxic.
- **WARNING! Fuse:** Please replace the fuse only with the same type and amperage in order to avoid fire hazards.
- **WARNING! Disassembly:** Do not open or disassemble the battery system.

Please see page 30 for more information on the specifications and parameters of this battery.

Product Overview

Fig. 1

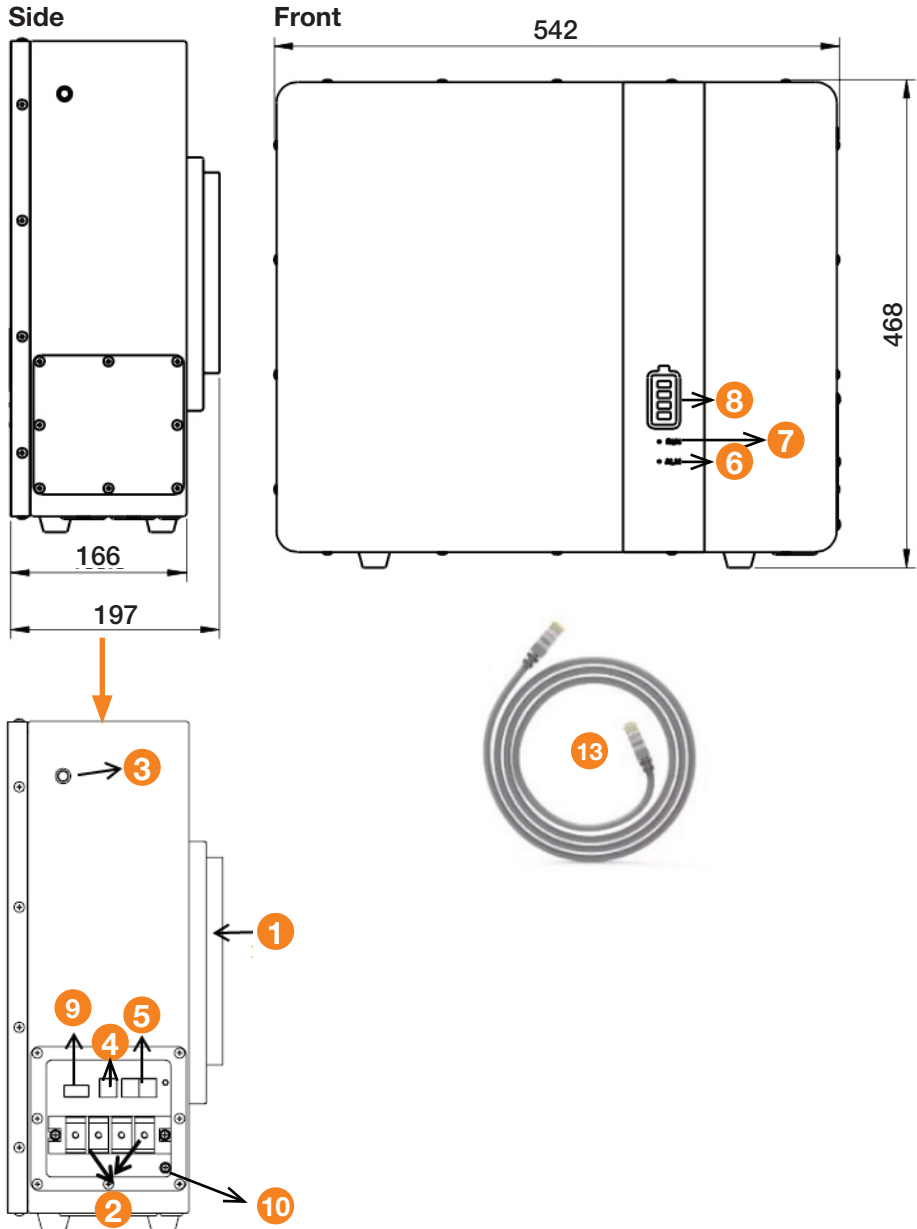

Product Overview (Cont.)

Scope of delivery

A Parts list

- 1 Wall Mount
- 2 Wiring Block
- 3 Battery Management System (BMS) Switch
- 4 CAN2.0B COMM to inverter / RS485 COMM to inverter
- 5 RS485 COMM to parallel battery / RS485 COMM to parallel battery
- 6 LED indicators
- 7 Red alarm indicator
- 8 SOC indicators
- 9 DIP switches
- 10 Grounding enclosure

B Accessories

- 11 Red power cable (1-3 m) (not shown)
- 12 Black power cable (1-3 m) (not shown)
- 13 RJ45 cable (1-3 m)

C Documentation (not shown)

Installation manual

Data sheet

Warranty certificate

NOTE: All measurements are in millimetres.

NOTE: Due to continued product improvement, images and illustrations in this manual may vary slightly from the product purchased. All images in this manual are for reference purposes only. Parts are not necessarily pictured to scale.

Product Overview (Cont.)

Battery Panel Diagram (Fig. 2)

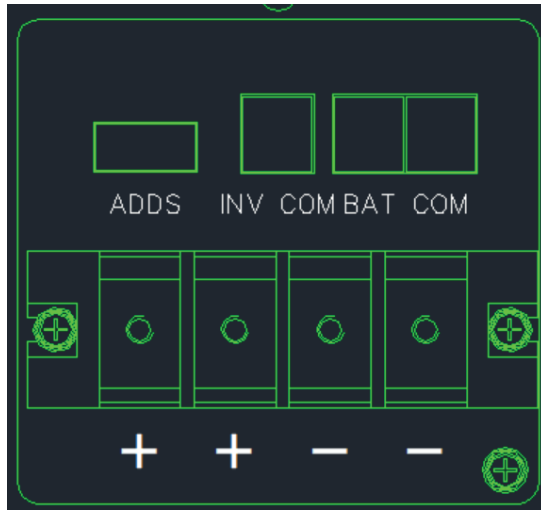

Battery Interface Image (Fig. 3)



Getting Started

Unpacking

- This product has been packaged to protect it against transportation damage. Unpack the battery and lay out the separate components. Keep the original packaging carton and materials in a safe place. It will help prevent any damage if the product needs to be transported in the future. In the event that the packaging materials are to be disposed of, please recycle them where possible.
- Plastic wrapping can be a suffocation hazard for babies and young children, so ensure all packaging materials are out of their reach and disposed of safely.
- Inspect the home battery for visual damage. Unwind the cords to their full lengths and inspect them for any damage. Do not use the appliance if the appliance or its cord have been damaged or are not working properly, or if any parts are missing (see page 7 for a full list). In case of damage or missing parts, contact our after sales support centre for advice.
- Make sure you have read and understood all instructions and warnings in this manual. Refer to the Product Overview, pages 6–8, to familiarise yourself with the product and identify all parts. Pay particular attention to the safety instructions on the previous pages.

IMPORTANT!

Installation and wiring must be completed in accordance with local electrical laws and regulations. **This battery MUST be installed by a qualified professional.**

WARNING!

- Make sure the main wire is in compliance with the standard of rated capacity of the battery to avoid hazards like electric shock or fire.
- Do not use the wall receptacle as the input power source for the battery, as its rated current is less than the battery's maximum input current. Otherwise the receptacle may be burned and destroyed.

Installation

Diagram of system

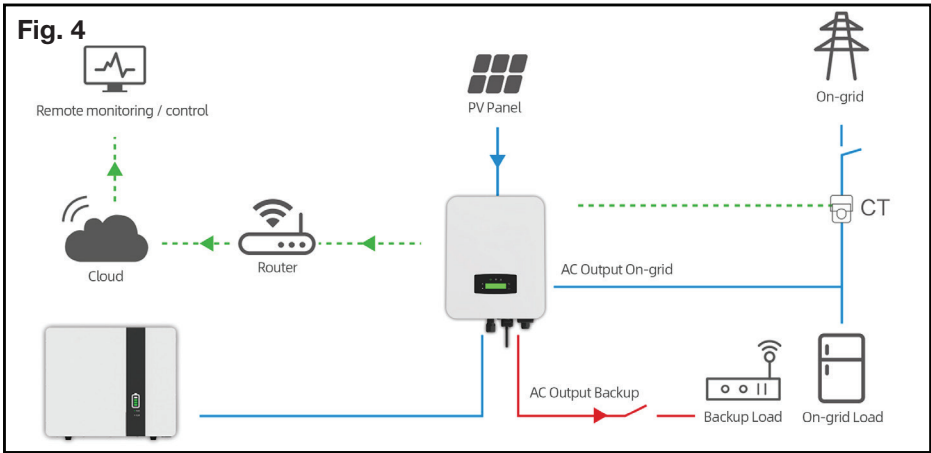

This system works through connection with solar panels and the grid. Firstly, your solar panels generate energy from the sun in the form of DC electricity. This then flows through an inverter, which converts the DC electricity into AC electricity for use in the home. Any extra electricity that is not being used is then stored in your 5 kWh Home Battery/Batteries. Then, when there is no sun, your home can be powered using the saved energy. This system is also connected to the grid, in case there is no sun and your battery is depleted, to ensure your home always has access to electricity.

System Installation

IMPORTANT!

Installation and wiring must be completed in accordance with local electrical laws and regulations. **This battery MUST be installed by a qualified professional.**

WARNING!

- Make sure the main wire is in compliance with the standard of rated capacity of the battery to avoid hazards like electric shock or fire.
- Do not use the wall receptacle as the input power source for the battery, as its rated current is less than the battery's maximum input current. Otherwise the receptacle may be burned and destroyed.

Installation (Cont.)

Installation Location

- The installation location of this product is key. It should be installed indoors in a location that can be accessed conveniently for maintenance purposes. The installation location should also allow for sufficient space for pedestrian passage.
- This equipment is not suitable for use in locations where children are likely to be present.
- This appliance should only be installed on a sturdy wall that is strong enough to support its weight (49 kg). It should be installed using the included bracket and appropriate screws and tools.
- There should be sufficient room between the battery/batteries and any other objects. The battery should be installed at least 50 cm away from any walls (aside from the wall that it has been mounted on), or other batteries. It should be installed at least 5 m away from any heat sources.

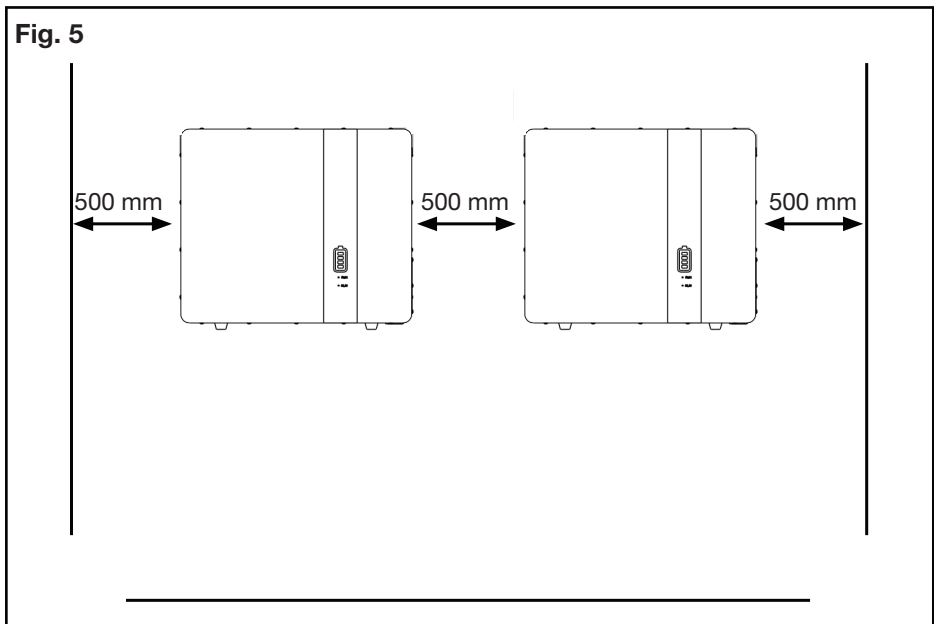

NOTE:

- Batteries **MUST** be installed indoors.
- Batteries **MUST** be installed at least 5 metres from any heat source.
- Batteries **MUST** be installed in a shaded area.

Installation (Cont.)

Installation Procedure

WARNING! Make sure the main wire is in compliance with the standard of rated capacity of battery to avoid hazards like electric shock or fire.

WARNING! Do not use the wall receptacle as the input power source for the battery, as its rated current is less than the battery's maximum input current. Otherwise the receptacle may be burned and destroyed.

- Prior to installation, unpack and check the quantity and appearance of the battery and parts supplied (see page 9 for more information).
- Select the installation area (see page 11 for more information), ensure it is clear and that you have the correct tools.
- Place the wall-mounting bracket onto the appropriate area of the wall. Ensure it is level.
- Using a drill (with a drill bit that is suitable for the type of wall that you are drilling into), drill 6 M8 bolts (not included) through the holes of the rack and into the wall (see Fig. 6 for placements).

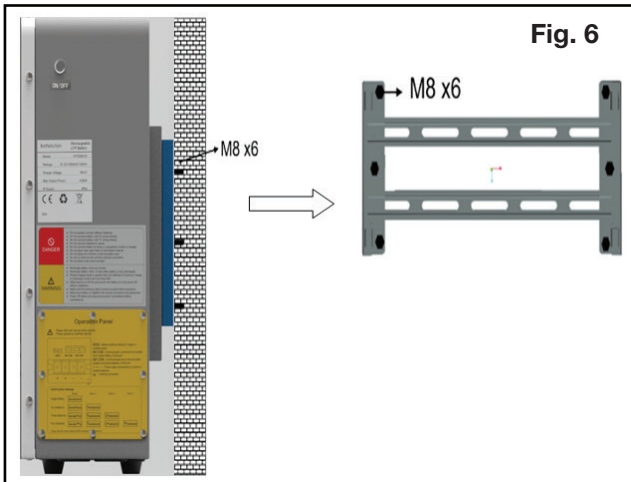

- Ensure the bracket is secured to the wall and is sturdy before attempting to hang the battery from it.
- Lift the battery (**CAREFUL! This battery is heavy!** Multiple people or specialised machinery is required) and hook the battery onto the bracket.
- Measure the battery voltage with a multimeter. The general factory voltage of the battery should be 52-53 V.

Installation (Cont.)

- Prior to wiring, check the anode and cathode of the battery. The anode and cathode terminals should **MUST** be connected correctly.
- During battery connection, please wear protective gloves. When using metal tools, such as a torque wrench, please use insulating packaging so that the two ends of the metal tools will not make contact with the positive and negative terminals of the battery at the same time, to avoid a short-circuit.
- Before the battery is connected using the externally connected equipment, make sure that this equipment has been disconnected. Check whether the connecting polarity of the battery and total voltage are correct, then connect the battery anode with the equipment anode and battery cathode with the equipment cathode and fix the connecting line.
- During movement and installation, the battery must be handled gently. Ensure it is not dropped or impacted. The battery must not be thrown or beaten to avoid damaging the battery and creating a potential safety hazard.
- Do not touch the surface of the battery box with the sharp part of any tool to avoid scratching or damaging the battery box.
- Do not disassemble the battery box without authorization.
- Do not put any article made of metal conductive material together with the battery or assemble it into the battery box.

Operation Instruction for Installation

Prior to installation, please check whether the battery is functioning normally:

- Press the POWER key at the bottom of the plate for startup. During startup, four capacity indicator lights on the front panel, the ALM alarm indicator light (red) and the green RUN running indicator light will illuminate. Check whether all of these lights illuminate normally.
- After they have illuminated, the ALM alarm indicator light will go out, the RUN running indicator light will continue to illuminate, and the capacity indicator lights will illuminate to show the battery's capacity.
- If the ALM alarm indicator light flashes after startup, it means that the battery has an alarm. A newly installed battery will seldom have an alarm. The most common alarm is a battery undervoltage alarm (which results from non-use of the battery for a long time). This type of alarm will most likely stop after charging the battery for 30 seconds. If the alarm is still there after this period, please press the reset key (RST) for 10 seconds, until all LEDs light up to show that the battery has been reset. If the alarm light is no longer illuminated, the battery may be used as normal. Otherwise, contact our after sales support team.

Installation (Cont.)

Installation of the lithium battery, wiring and startup;

- Make sure the battery pack is switched off, before installing it onto the wall-mounting bracket.
- The anode and cathode of the battery pack should be connected to the switching mode power supply or inverter.
- Please note that the switching mode power supply and inverter should be disconnected from the AC.
- Press the POWER key on one of battery packs to switch it on. This will activate any other batteries that are connected in parallel (or you can press the POWER button of each battery pack successively). The battery will then enter working mode.
- Lastly, apply AC to the power supply equipment such as switching mode power supply and inverter to make the whole standby system run.

Single Battery Installation

IMPORTANT!

Installation and wiring must be completed in accordance with local electrical laws and regulations. **This battery MUST be installed by a qualified professional.**

WARNING!

- Make sure the main wire is in compliance with the standard of rated capacity of the battery to avoid hazards like electric shock or fire.
- Do not use the wall receptacle as the input power source for the battery, as its rated current is less than the battery's maximum input current. Otherwise the receptacle may be burned and destroyed.

1. Ensure the POWER switch is in the OFF position before installation.
2. Turn off all connected devices before connecting to the battery.
3. Follow the wiring setup shown on the next page (Fig. 8).

Installation (Cont.)

Fig. 8



Connecting the wires

WARNING!

Ensure the power is completely switched off before installing any wires! Failure to take the correct precautions can result in electrocution, serious injury, or death. See pages 3-5 for comprehensive safety instructions, as well as specific safety information on pages 12-13.

- To connect the wires to the battery, unscrew the plastic red or black screw cap from the positive/negative terminal.
- Remove the top plastic part from the terminal.
- Unscrew the metal nut from the bolt inside. Remove the washer beneath it.
- Place the metal loop from one end of the corresponding wire over the bolt, and attach the washer and nut back over the top, screwing them securely into the bolt, to hold the wire in place.
- Replace the top plastic part of the terminal and screw the top plastic cap over the end of the bolt.

Installation (Cont.)

- Connect both the positive and negative power lines of the inverter and battery, according to the setting of the circuit breaker (Fig. 9).
- Please note, the cable from circuit breaker to inverter is not provided.

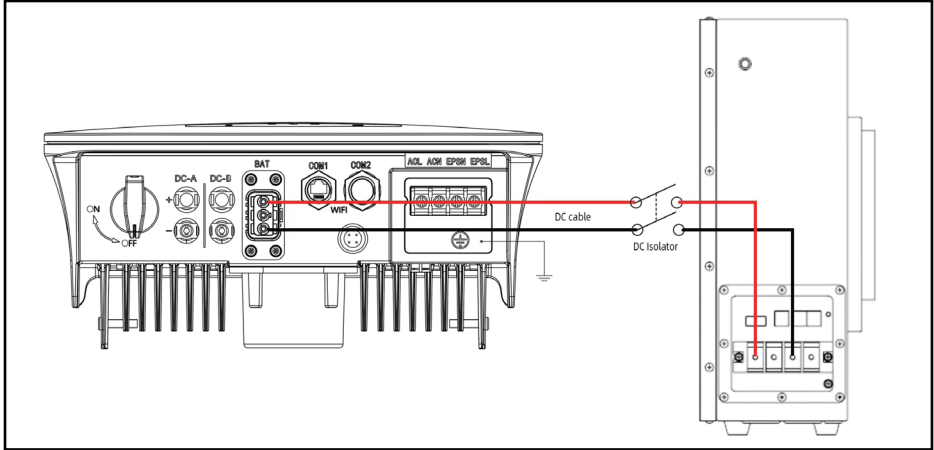

- Use the screw hole indicated with a red square to install another grounding wire (Fig. 10 - please see pages 6 and 7 for an expanded view and explanation of this diagram).

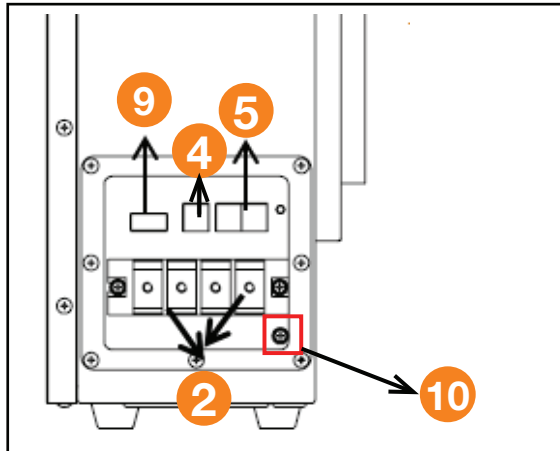

- Please note, the grounding cable is not provided.
- For Australian Market an overcurrent protection and isolation device that isolates both positive and negative conductors simultaneously is required between the battery and the inverter.

Installation (Cont.)

Software Installation

Optionally, you can install battery monitoring software onto your computer system, to fully configure the battery monitor the battery parameters.

Installation of Battery/Batteries in Parallel

IMPORTANT!

Installation and wiring must be completed in accordance with local electrical laws and regulations. **This battery MUST be installed by a qualified professional.**

WARNING!

- Make sure the main wire is in compliance with the standard of rated capacity of the battery to avoid hazards like electric shock or fire.
- Do not use the wall receptacle as the input power source for the battery, as its rated current is less than the battery's maximum input current. Otherwise the receptacle may be burned and destroyed.

Capacity Options

- The battery can be parallely connected for extending power (kW) and energy (kWh).
- The maximum power (kW) is limited by main cables from master battery to inverter.
- A maximum of 8 battery packs can be connected in parallel. See below for example configurations.



One pack: 5.12 kWh



Two packs: 10.24 kWh

Installation (Cont.)



Four packs: 20.48 kWh

And so on.

Parallel Communication

- When multiple packs are connected in parallel, the RS485 interface is used as the parallel communication interface. The client pack can read the sum of the server battery data of all parallel packs through the RS485 communication.

Two packs RS485 parallel connection 1:

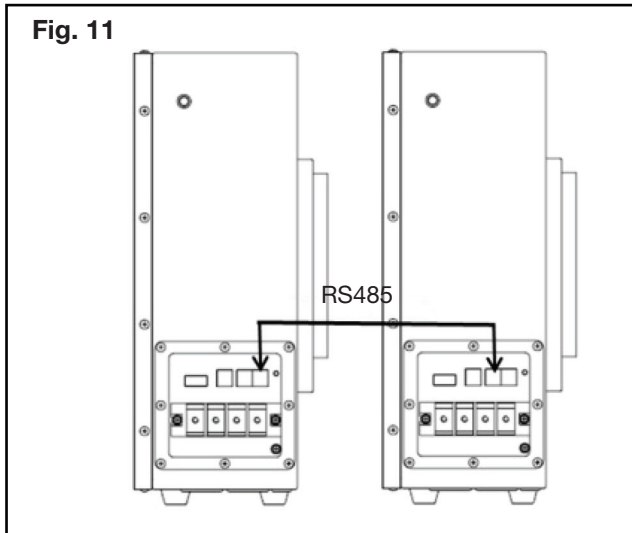

Installation (Cont.)

- In parallel system, choose the positive power line of the inverter and last battery, according to the setting of the circuit breaker (Fig. 12). Just plug the power line in breaker.

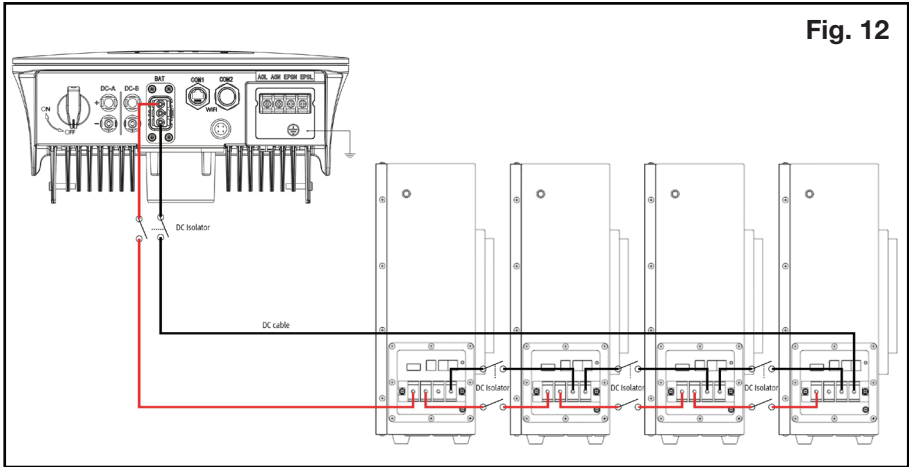
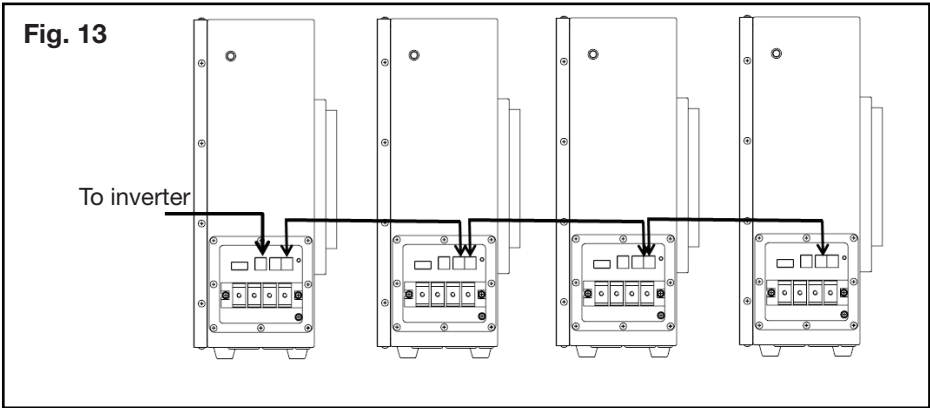

Fig. 12

- Please note, the cable from circuit breaker to inverter is not provided.
- For Australian market, to comply with AS/NZS 5139 an a overcurrent protection and isolation device between each parallel battery
- The BMS of each battery has the function of current monitoring, temperature monitoring, active protection.
- For parallel batteries an overcurrent protection and isolation device that isolates both positive and negative conductors simultaneously is required between each parallel battery and active disconnection.

Installation (Cont.)

More than two packs RS485 parallel connection 2:



Recommended Settings

- A lithium battery pack is not as the same as lead-acid battery. Therefore, the devices that you connect with the battery pack for charging and discharging, such as inverters, MPPT charger controllers or UPS, must have the pre-settings below implemented before you start.

Setting	AS-5KW-LB2
Max. Charging Voltage	57 V
Floating Charging Voltage	57 V
Max. Charging Current	N*(40-10)A
Max. Discharging Current	N*(75-10)A
Cut-off Voltage	45 V

Note: “N” represents the number of battery packs connected in parallel.

Installing the battery/batteries

1. Ensure the POWER switch is in the OFF position before installation.
2. Turn off all connected devices before connecting to the battery.
3. Connect the following wires as indicated in the diagrams on pages 18-20 (Fig. 11 - Fig. 13).

Battery Management System

When the BMS switch is turned off, the BMS can be put to sleep and the charge and discharge MOS transistors will be turned off at the same time. Normal operation will be restored after the BMS is turned back on.

NOTE: Please do not turn on the BMS switch when the product is not in use to avoid self-consuming the lithium battery.

Installation (Cont.)

- Please connect the inverter and battery BMS as outlined in the diagram below (Fig. 14)

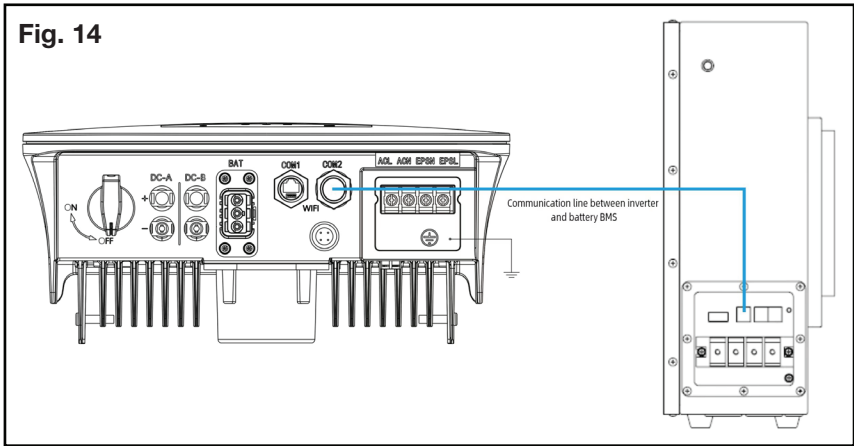

Installation (Cont.)

DIP Switches

For multi-battery communication where the battery packs are connected in parallel, use the DIP switch to distinguish different pack addresses. The hardware address can be set by the DIP switch on the panel below.

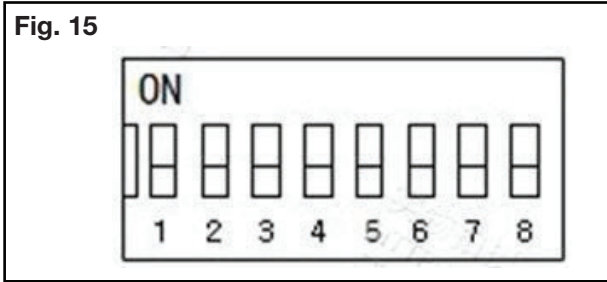

Fig. 16

	Client	Server	
Single Battery			
Two Batteries			Server 1
Three Batteries			Server 2
Four Batteries			Server 3
Five Batteries			Server 4
Six Batteries			Server 5
Seven Batteries			Server 6
Eight Batteries			Server 7

For example, the blue frame is the settings for 4 batteries.

Startup and Shutdown Procedure

Boot sequence:

1. Click Battery Management System (BMS) Switch.
2. The SOC indicators are on, the RUN indicator is always on, and the ARM indicator is off.
3. Turn on the DC isolation connecting the inverter to the battery.

Closing sequence:

1. Click Battery Management System (BMS) Switch.
2. The SOC indicators are off, the RUN indicator is off, and the ARM indicator is off.
3. Turn off the DC isolation connecting the inverter to the battery.

Note: For Australian Market an overcurrent protection and isolation device that isolates both positive and negative conductors simultaneously is required between the battery and the inverter.

Equipment Interface Instructions

Address Switch Function (only in parallel)





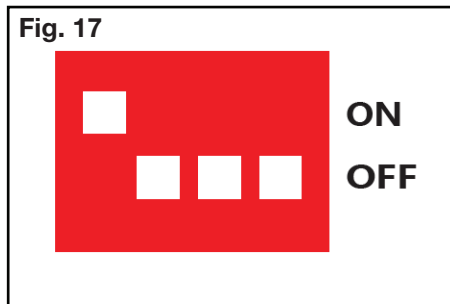

When the batteries are set up to work in parallel, the host/client pack and server packs need to be addressed as follows:

	Dial code switch position				Instruction
	#1	#2	#3	#4	
0	OFF	OFF	OFF	OFF	No cascade, use single
1	ON	OFF	OFF	OFF	Set to Pack1 (Host/Client)
2	OFF	ON	OFF	OFF	Set to Pack2
3	OFF	OFF	ON	OFF	Set to Pack3
4	OFF	OFF	OFF	ON	Set to Pack4
5	ON	OFF	ON	OFF	Set to Pack5
6	OFF	ON	ON	OFF	Set to Pack6
7	ON	ON	ON	OFF	Set to Pack7
8	OFF	OFF	OFF	ON	Set to Pack8
9	ON	OFF	OFF	ON	Set to Pack9
10	OFF	ON	OFF	ON	Set to Pack10
11	ON	ON	OFF	ON	Set to Pack11
12	OFF	OFF	ON	ON	Set to Pack12
13	ON	OFF	ON	ON	Set to Pack13
14	OFF	ON	ON	ON	Set to Pack14
15	ON	ON	ON	ON	Set to Pack15











Operations

LED Indicators:

System	Status	RUN	ALM	SOC				Definition
								
Switch on	Sleeping	OFF	OFF	OFF	OFF	OFF	OFF	All OFF
Standby	Normal	ON	OFF	SOC Indicators				Standby
Charging	Normal	ON	OFF	SOC Indicators				Flashing
	OC ALM	ON	Flashing	SOC Indicators				Flashing
	OV ALM	ON	OFF	SOC Indicators				
	OT ALM	ON	Flashing	SOC Indicators				
Discharging	Normal	Flashing	OFF	SOC Indicators				SOC Indicators
	Alarm	Flashing	Flashing					
	All Protections	OFF	ON	OFF	OFF	OFF	OFF	Fully discharged or 48 hours without instructions - entering sleep mode
	UV Protections	OFF	OFF	OFF	OFF	OFF	OFF	Stop discharging

SOC Indicators

The four green LED lights display the real-time SOC capacity of the lithium battery pack.

Status	Charge				Discharge			
SOC	L4 	L3 	L2 	L1 	L4 	L3 	L2 	L1 
0 ~ 25%	OFF	OFF	OFF	Flashing	OFF	OFF	OFF	ON
25 ~ 50%	OFF	OFF	Flashing	ON	OFF	OFF	ON	ON
50 ~ 75%	OFF	Flashing	ON	ON	OFF	ON	ON	ON
≥75%	Flashing	ON	ON	ON	ON	ON	ON	ON
RUN 	ON				Flashing			

Troubleshooting

If the system is not operating correctly, please see the table below for troubleshooting options.

Issue	Possible Cause	Solution
No indicator or alarm on the front display panel	Sleep mode	Press “Reset” to enter normal operation mode
The indicator light will turn on for (approx.) 3 seconds and off even after resetting	Battery voltage too low	Charge battery immediately
Red LED flashing when in standby mode	Battery cell low voltage	Charge battery immediately
Red LED flashing when charging	Alarm indicating protection when charging	Check the BMS for the alarm, then check the charge voltage and current.
Red LED flashing when discharging	The battery power is too low and will shutdown	Charge battery immediately
RED LED illuminating continuously	There is a problem with the internal workings of the battery	Contact our after sales support team

The specific nature of any other issues with this product can also be determined based on the following variables:

1. Whether the battery can be switched on.
2. If the battery can be switched on, check if the red alarm light the red light is off, flashing or on.
3. If the red light is off, check whether the battery can be charged/discharged.

Preliminary determination steps:

If the battery cannot be turned on, and lights are all not flashing or illuminated, ensure the external switch is ON. If it is ON, the RUN light is flashing, the external power supply voltage is 51.2 V (or greater), and the battery is still unable to turn on, please contact our after sales support team (see bottom of the page).

If the battery can be turned on, but the red light is illuminated, and the battery cannot be charged or discharged, the system is abnormal - please check the following:

- **Temperature:** If the temperature is above 55°C or under -10°C, the battery will not function. Please move the battery to a location that is in the normal operating temperature range (between -10°C and 55°C).

Troubleshooting (Cont.)

- **Current:** If current is larger than 75 A, battery protection will turn on. To fix this, check whether current is over this limit. If it is, change the settings on the power supply side.
- **High Voltage:** If the charging voltage is above 57 V, the battery protection will turn on. To fix this, check whether the voltage is over this limit. If it is, change the settings on the power supply side.
- **Low Voltage:** When the battery discharges to 41.6 V or less, the battery protection will turn on. To fix this, charge the battery until red light turns off.

If the battery still cannot be charged or discharged, please see below:

- **Cannot be charged:** Disconnect the power cables and measure the voltage on the power side. If the voltage is 56.5~57 V, restart the battery, connect the power cable and try again.
- **Cannot be discharged:** Disconnect the power cables and measure voltage on the battery side. If it is under 41.6 V, please charge the battery. If the voltage is above 51.2 V and still cannot discharge, turn off the battery and contact our after sales support team.

If the fault is still cannot be located or fixed, turn off battery and contact after sales support.

Emergency Scenarios

Leaking Batteries: If the battery pack leaks electrolyte, avoid contact with the leaking liquid or gas. If you are exposed via:

- **Inhalation:** Evacuate the contaminated area and seek medical attention.
- **Contact with eyes:** Rinse eyes with flowing water for 15 minutes and seek medical attention.
- **Contact with skin:** Wash the affected area thoroughly with soap and water and seek medical attention.
- **Ingestion:** Seek medical attention.

Fire: DO NOT EXTINGUISH THE BURNING BATTERY WITH WATER! Only use a Hfc-227ea fire extinguisher.

Wet Batteries: If the battery pack is wet or submerged in water, evacuate the area and contact emergency services or an authorized dealer for technical support.

Damaged Batteries: Damaged batteries are dangerous and must be handled with the utmost care. They are not fit for use and may pose a danger to people or property. If the battery pack seems to be damaged, pack it in its original container, and the return it to an authorized dealer.

If none of these options diagnose or fix the issue, please contact our after sales support team at tempo.org/support or on 1300 886 605.

Other Useful Information

Storage

Before storing this battery, charge it at for least 7 hours. Store the battery covered and upright in a cool, dry location. The recommend long-term storage temperature is -10 °C - 35 °C.

During storage, recharge the battery every 3 months for 1-2 hours (assuming a storage temperature of -10 °C - 35 °C). This is to avoid damaging the battery.

Maintenance

- **WARNING!** The battery system operates with hazardous voltages. Repairs may be carried out only by qualified maintenance personnel.
- **DANGER!** Even after the unit is disconnected from the mains, components inside are still connected to the battery cells which are potentially dangerous.
- **WARNING!** Before carrying out any kind of service and/or maintenance, disconnect the batteries and verify that no current is present and no hazardous voltage exists in the terminals.
- **WARNING!** Only persons are adequately familiar with batteries and with the required precautionary measures may replace batteries and supervise operations. Unauthorized persons must be kept well away from the batteries.
- **DANGER!** Verify that no voltage between the battery terminals and the ground is present before maintenance or repair. In this product, the battery circuit is not isolated from the input voltage. Hazardous voltages may occur between the battery terminals and the ground.
- **WARNING!** Batteries may cause electric shock and have a high short-circuit current. Please remove all wristwatches, rings and other metal personal objects before maintenance or repair, and only use tools with insulated grips and handles for maintaining or repairing.
- **WARNING!** When replace the batteries, install the same number and same type of batteries.
- **WARNING!** When replace the parallel batteries, make sure the new battery is full charged.
- **WARNING!** Do not open or destroy batteries. Escaping electrolyte can cause injury to the skin and eyes. It may be toxic.
- **WARNING!** Please replace the fuse only with the same type and amperage in order to avoid fire hazards.
- **WARNING!** Do not disassemble the battery system.
- Recharge battery in every six months.
- Recharge battery within 10 days after battery is fully discharged.
- When the battery is being installed or repaired, make sure the battery is powered off - DO NOT disconnect, disassemble or repair by yourself.
- Do not drop, deform, impact, cut or spearing with a sharp object.
- Do not place near open flame or incinerate.
- Do not sit or put heavy things on battery.
- Keep away from moisture or liquid.
- Keep out of reach of children, animals or insects.
- In case of a fire, use a Hfc-227ea fire extinguisher, not water.

Other Useful Information (Cont.)

Service, repair and spare parts

CAUTION!

If your battery appears not to be operating correctly, contact our after sales support centre for advice. Do not attempt to repair the appliance yourself!

Please note that if you book a service, the appliance must be accessible for the technician to perform any necessary repair. If the battery is installed in such a way that the technician is concerned that damage will be caused to the appliance or your property, then they will not complete a repair.

This appliance must only be serviced by authorised personnel.

There are no spare parts available for purchase.

Other Useful Information (Cont.)

Battery Pack Technical Specifications

Model Number	AS-5KW-LB2
Nominal voltage	51.2 V
Rated capacity	100 Ah
Rated reserved energy	5120 Wh
Standard charging current	40 A
Maximum continuous charging current	40 A
Minimum continuous charging current	10 A
Total charging cut-off voltage	57.6 V
Cut-off voltage of charging monomer	3.6 V
Standard discharging current	66 A
Maximum continuous discharging current	75 A
Cut-off voltage of discharging monomer	2.6 V
Operating Temperature Range	0°C~55°C (Charge) -10°C~55°C (Discharge)
Transport or Storage Temperature Range	-10°C~35°C
Dimension (WxDxH)	542 x 197 x 468 mm
Weight	49 kg
Ingress Protection Rating	IP65
External DC Isolator	Min. 120 A
Power Consumption	<1 W (Work), <100 mW (Sleep)
Communication Interface	CAN/RS-485
Differential pressure	Differential pressure at the discharging end (2.5 V for monomer) ≤300 mV
	Differential pressure at the charging end (3.65 V for monomer) ≤150 mV

Other Useful Information (Cont.)

Compliance

This appliance has been fully tested and meets all requirements as set out by standards AS IEC 62691 & AS/NZS 62368 & EN 61000.



The RCM Mark (Regulatory Compliance Mark) indicates that the product complies with the relevant guidelines of the ACMA as well as corresponding government requirements for the safety of electrical devices.

Responsible disposal



Packaging materials are recyclable. Please dispose of them responsibly for recycling.



At the end of its working life, do not throw this appliance out with your household waste. Electrical and electronic products contain substances that can have a detrimental effect on the environment and human health if disposed of inappropriately. Observe any local regulations regarding the disposal of electrical consumer goods and dispose of it appropriately for recycling.

Contact your local authorities for advice on recycling facilities in your area. Or find recycling scheme services listed on Planet Ark's website at www.recyclingnearyou.com.au, or call Planet Ark on 1300 733 712.

Other Useful Information (Cont.)

Licensed installer/electrician details

Please ask your licensed installer/electrician to fill in the details below so you have them on record should you need to contact the installer in the future.

Proof of professional installation is also required for warranty claims.

Please fill in the details below:

Name of licensed installer:

Licence number:

Date of installation:

Signature:

Installer's Notes

Installer's Notes (Cont.)

Installer's Notes (Cont.)

Warranty returns

Should you for any reason need to return this product for a warranty claim, make sure to include all accessories with the product.

Product does not work?

If you encounter problems with this product, or if it fails to perform to your expectations, make sure to contact our After Sales Support Centre on (AU) 1300 886 605 for advice.

For an electronic copy of this manual, please contact our after sales support centre.

Distributed by Tempo (Aust) Pty Ltd ABN 70 106 100 252

PO BOX 132, Frenchs Forest NSW 1640, Australia

Customer Helpline:

(AU) 1300 886 605

Web Support: tempo.org/support

IM Version No: V1.0

Issue: December 2022

After Sales Support

☎ 1300 886 605 (AUS) | 🌐 tempo.org/support